

Growing a sustainable future

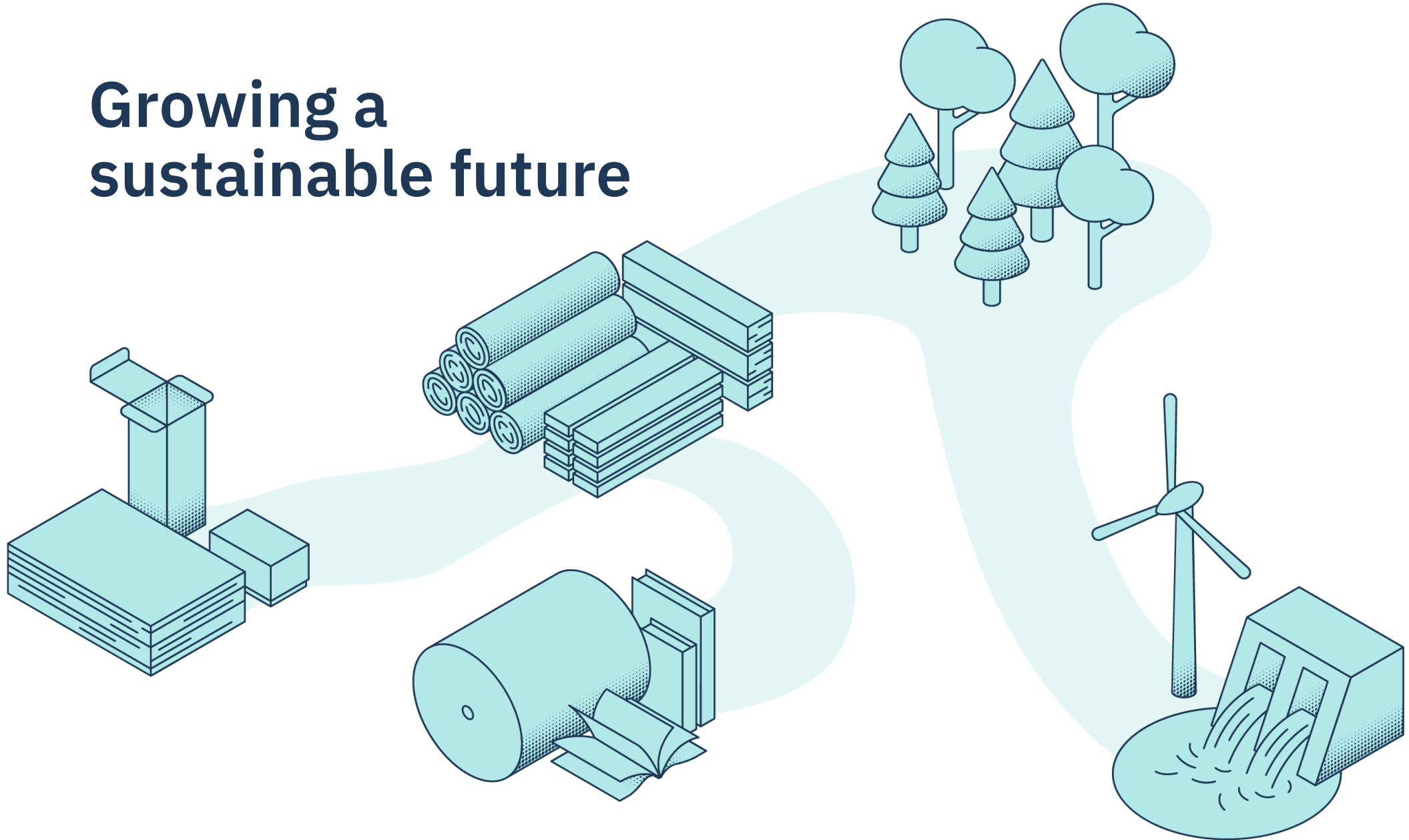

Growing a sustainable future



We grow houses

Leftovers are converted into renewable packaging and paper
We harvest the energy that blows and runs through our forests

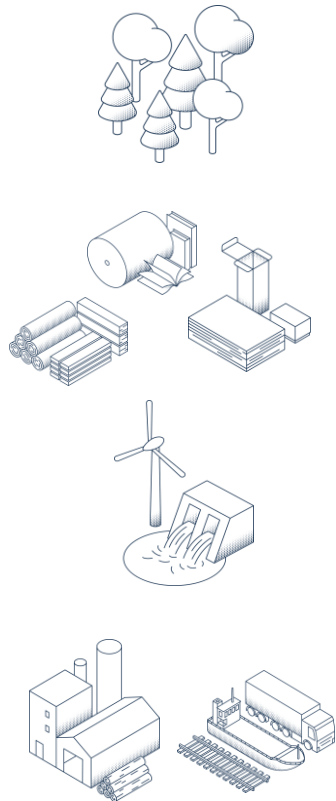

1.3
Million tonnes
CO₂e

Carbon sequestration

+

4.7
Million tonnes
CO₂e

Storage and substitution from wood products (3.1), paperboard and paper (1.6)

+

1.9
Million tonnes
CO₂e

Substitution from renewable energy production

-

0.7
Million tonnes
CO₂e

Fossil emissions reduced by 90%

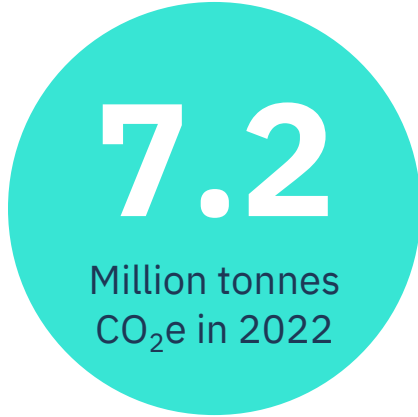

Expanding wood products and wind power

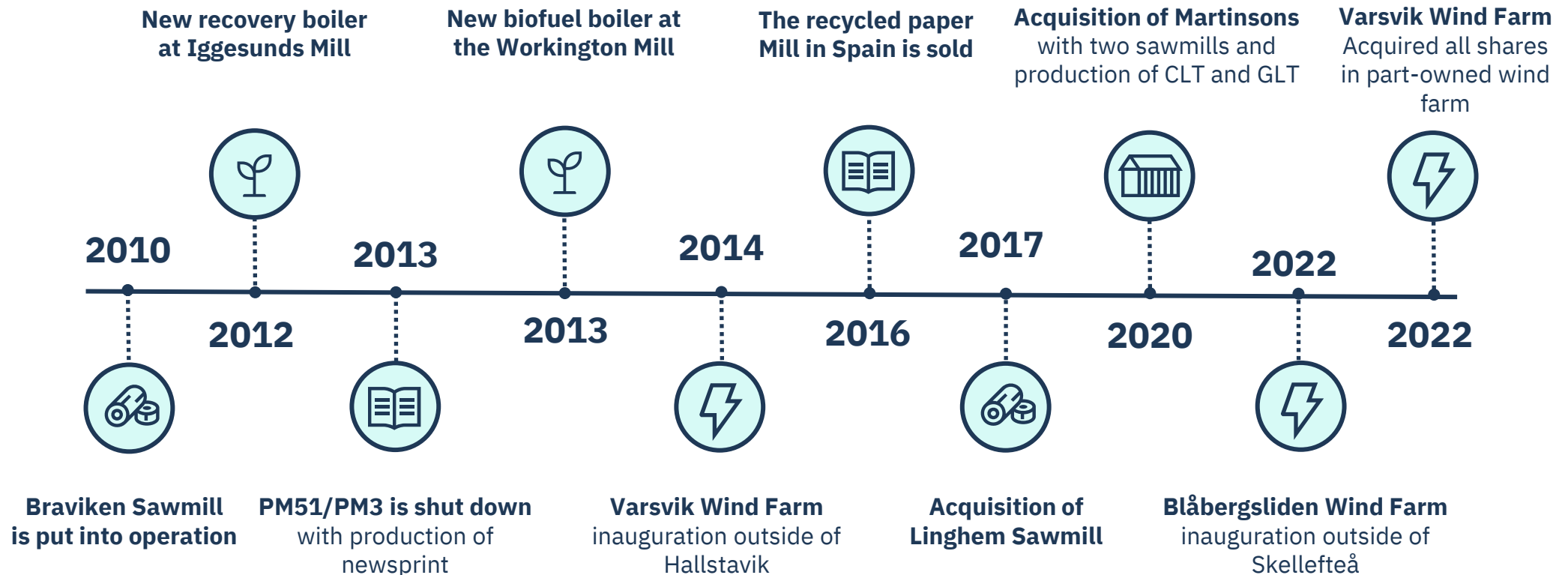

Forest

1.3 million ha total land area

1.0 million ha productive forest land

Forest growth and future harvests will increase through active and sustainable forestry. A strong position in the wood market will enable the development of Holmen's production facilities

Growing forests with increased biodiversity

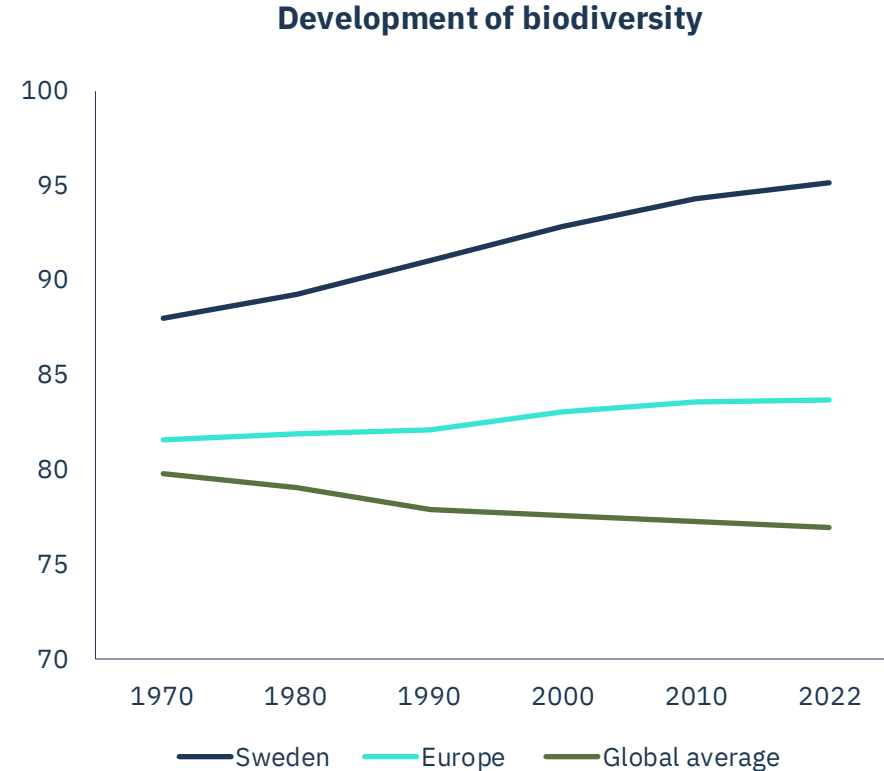
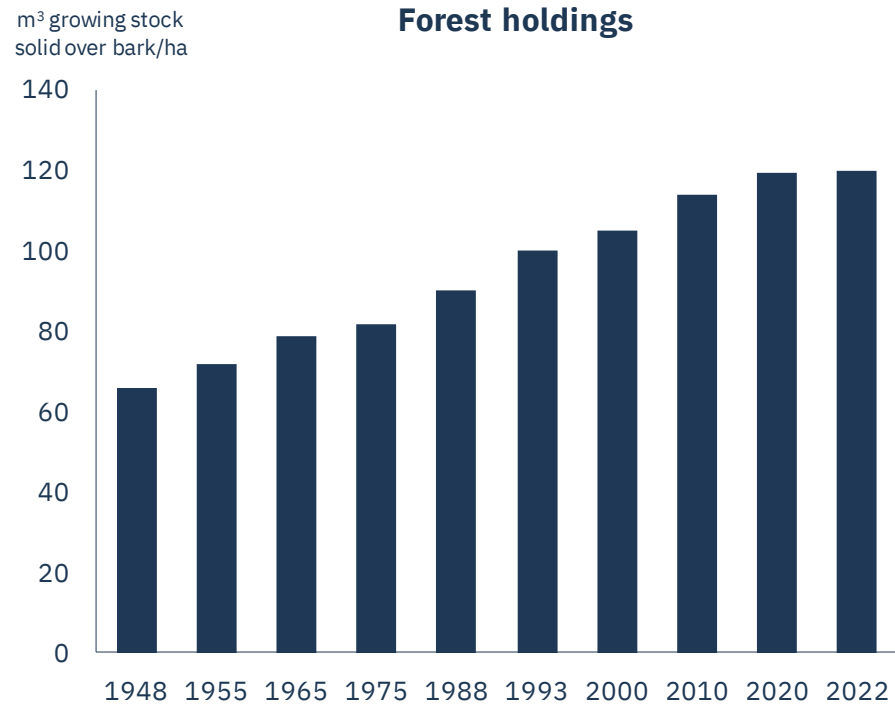

Gradually growing harvest

Prices has risen in line with inflation

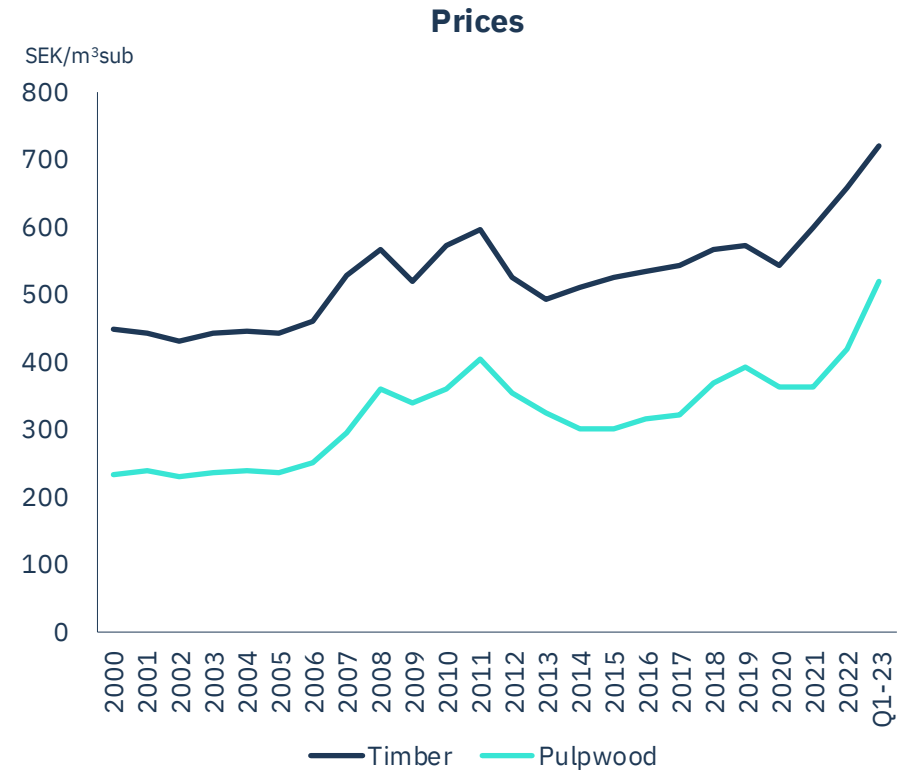
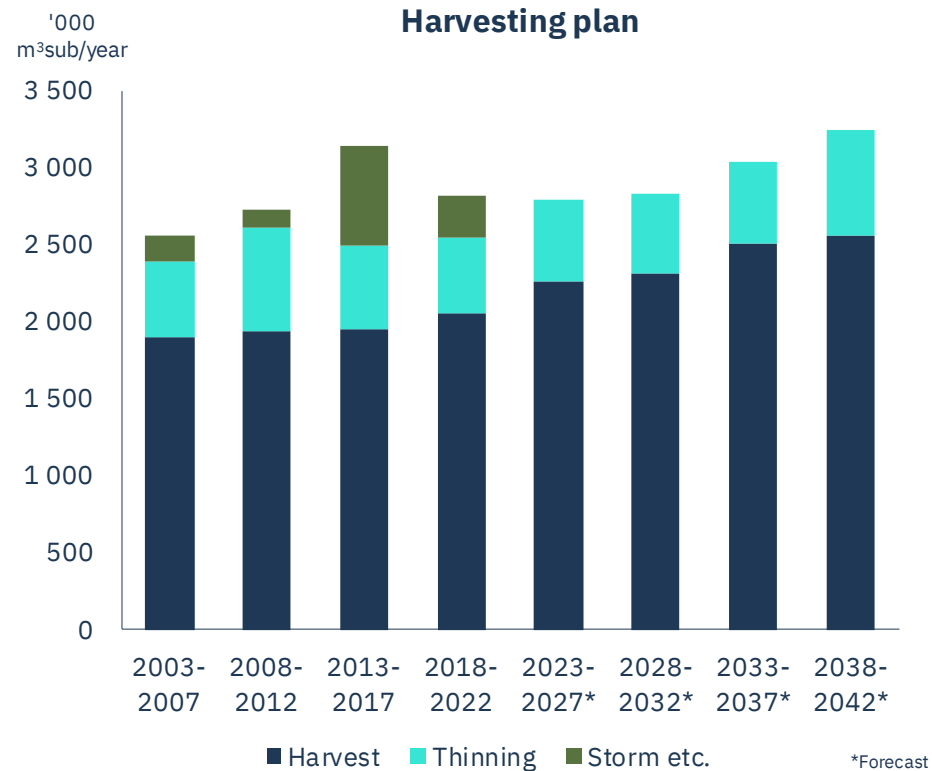

Competition for pulpwood intensifying

Solid demand for timber

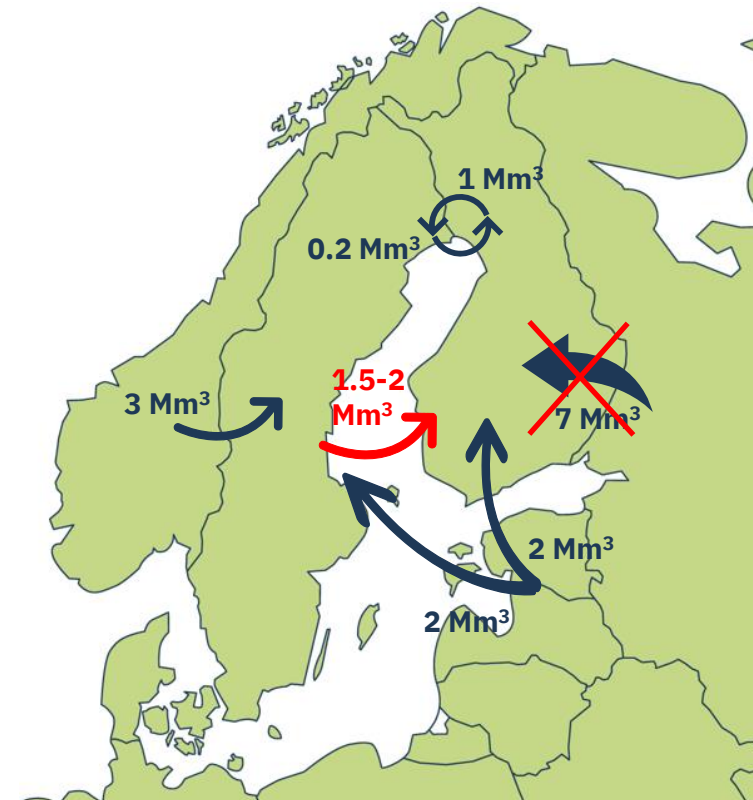
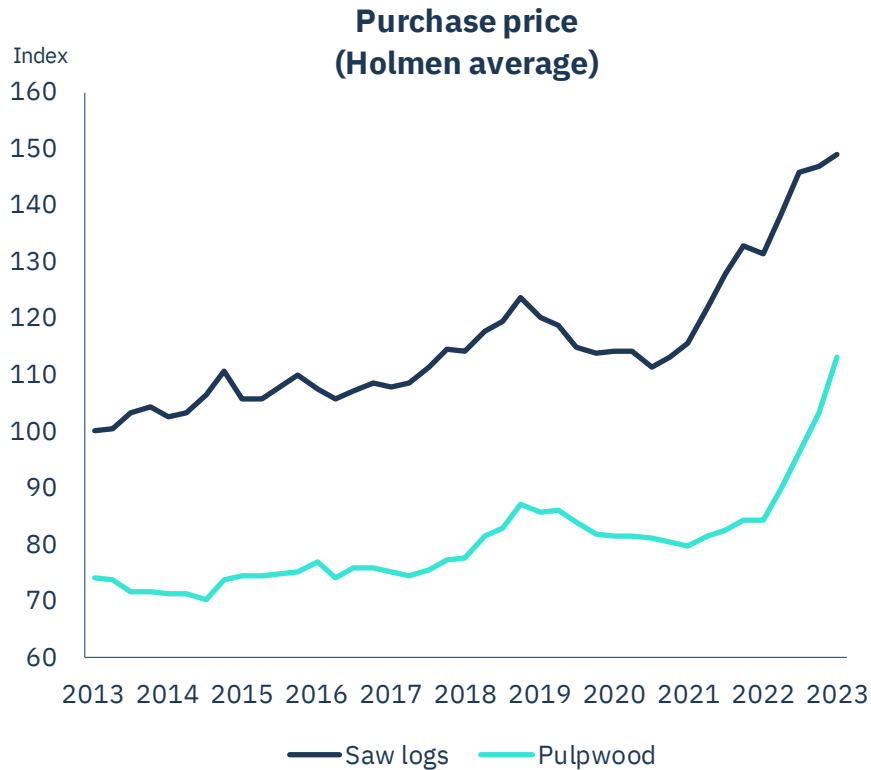

Increasing forest cash flow

Prices 30% higher than trend

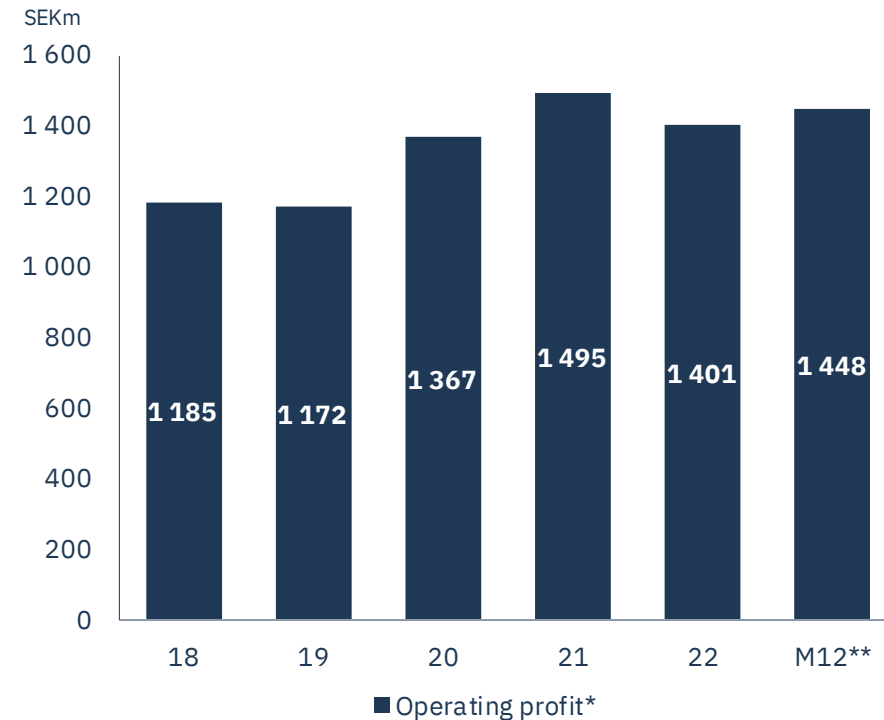
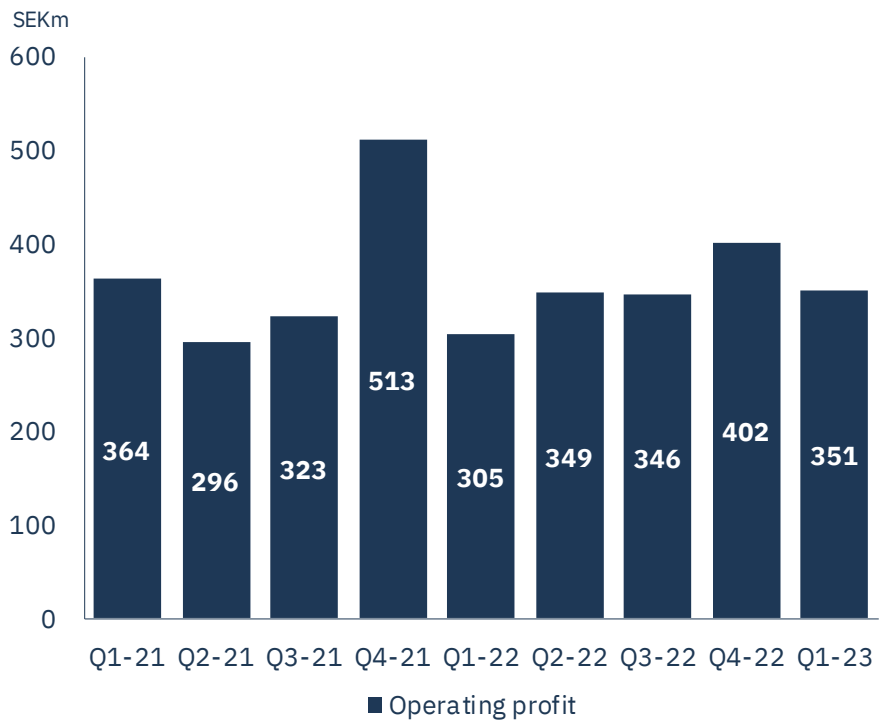

Forest book value SEK 52 bn

Based on 3 years transactions (2020-2022)

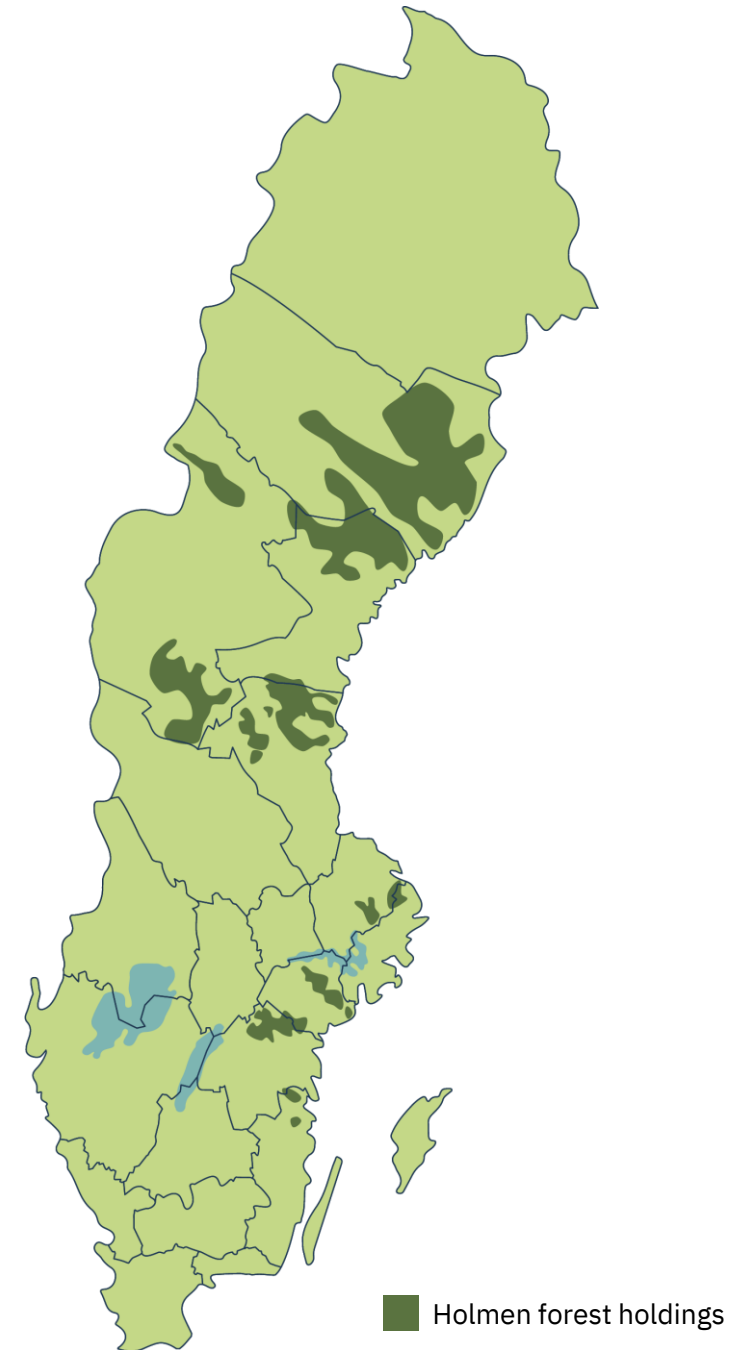
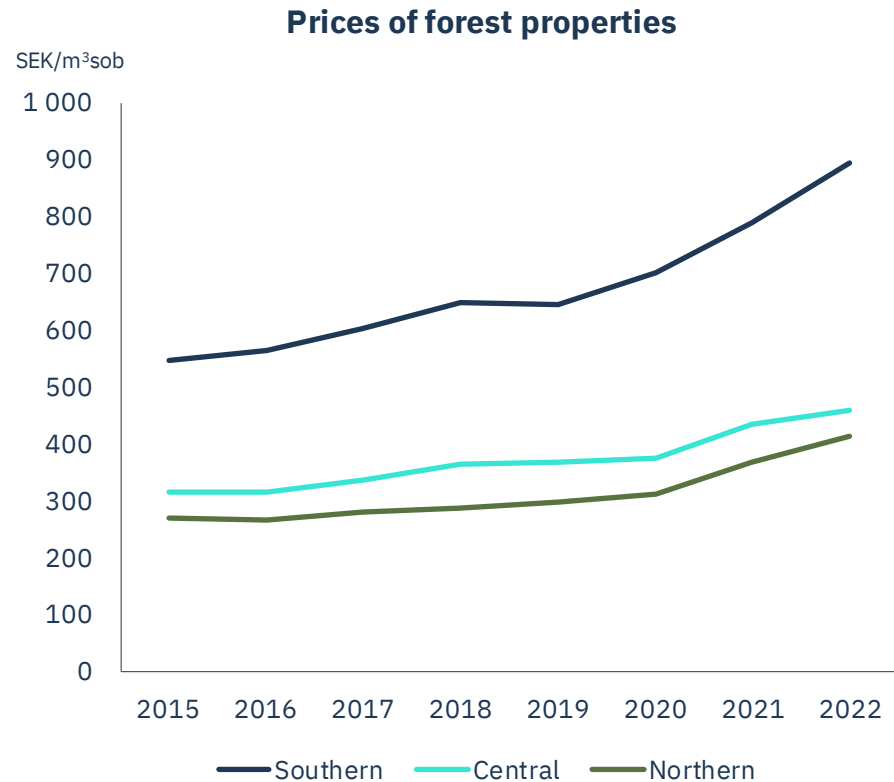

H



New revenue opportunities
for a land owner

Paperboard

550 000 tonnes per year

The Paperboard business will develop on the basis of its position as a market leader in the premium segment for renewable consumer packaging



Slowing demand but stable prices

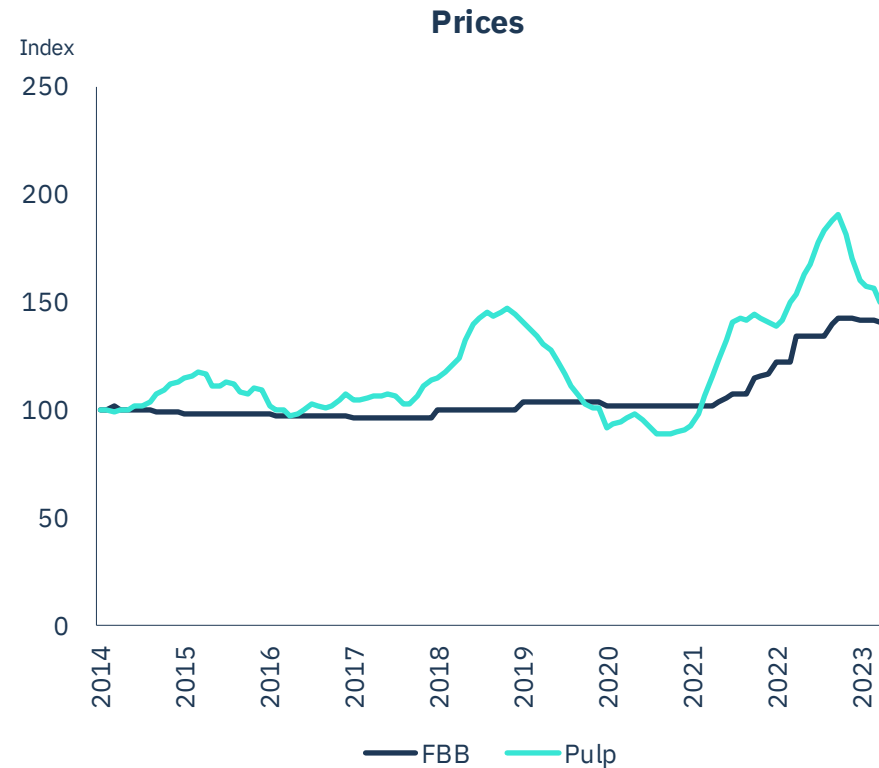
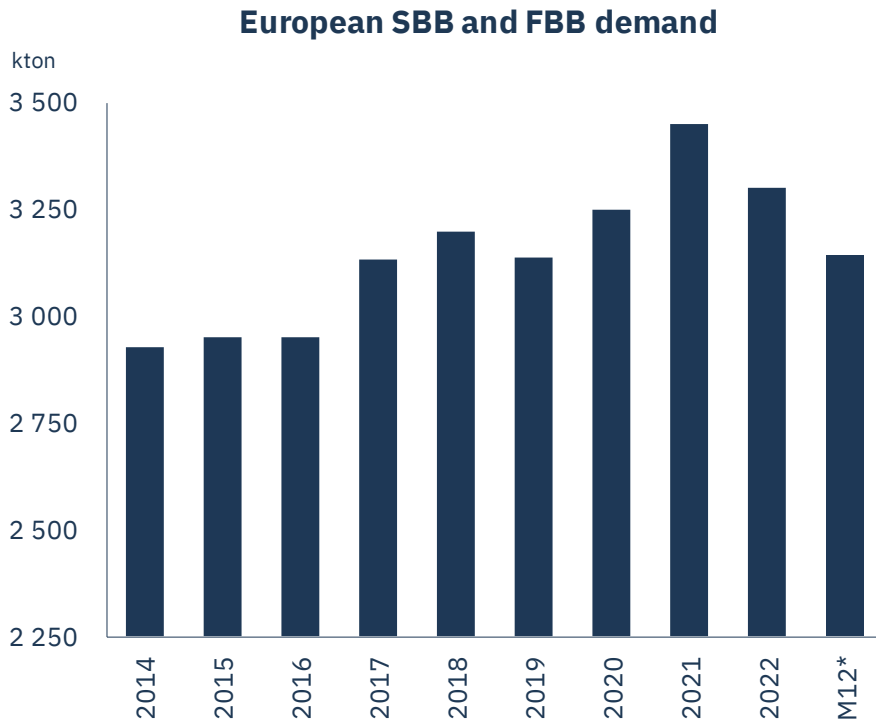

Price increases in line with cost inflation

Benefitting from electricity sales

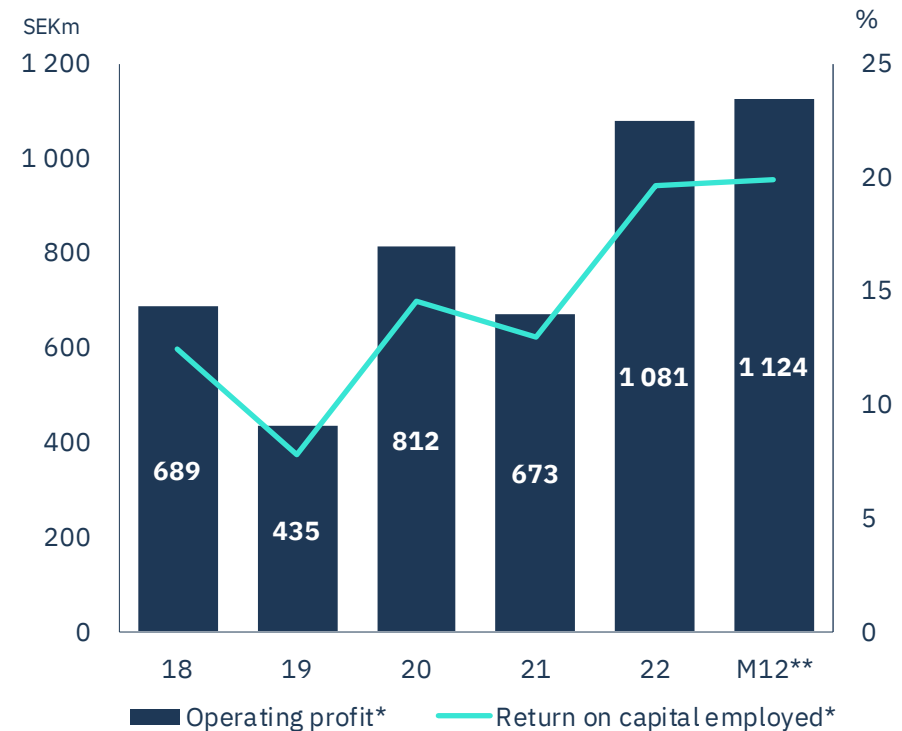
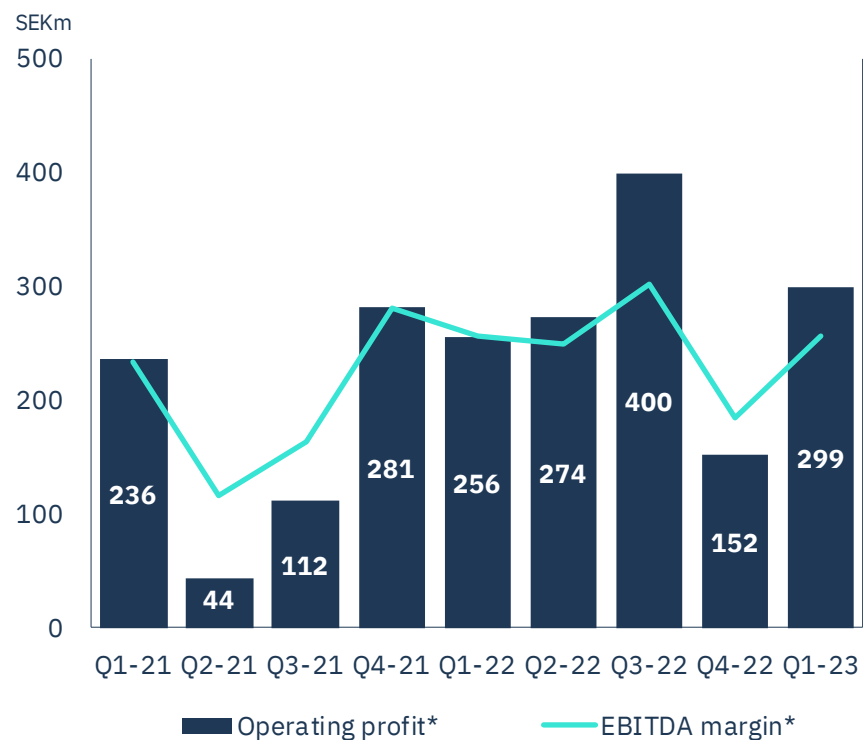

Ambition to grow Iggesund Mill 25%

5 year investment programme



Grow sales in premium segment

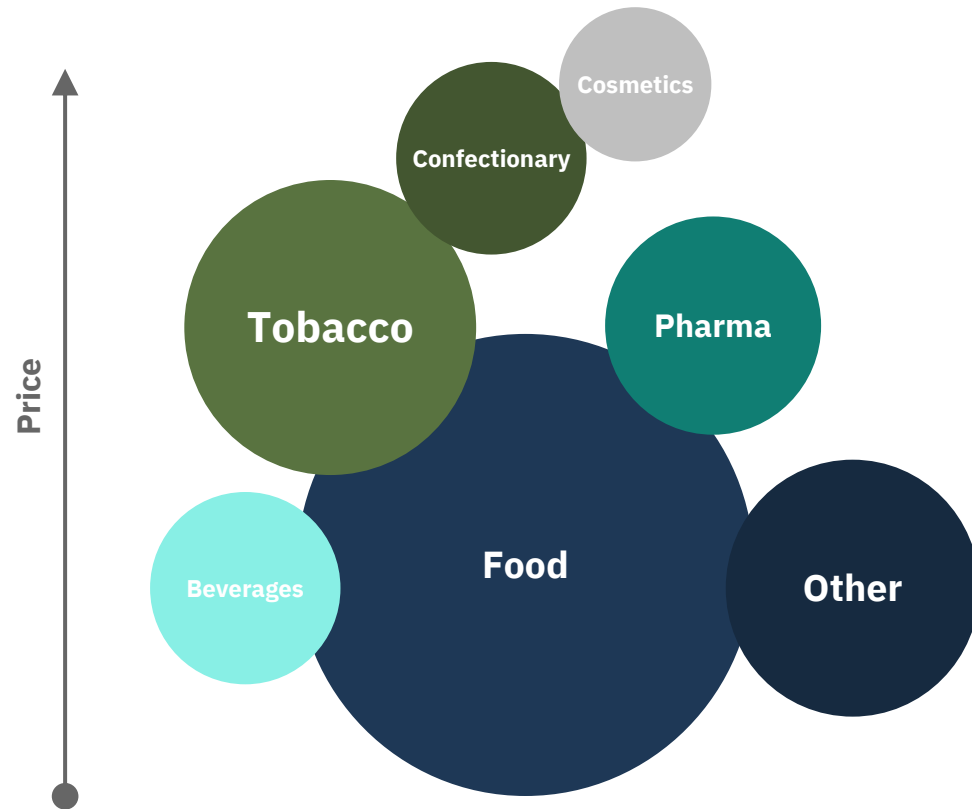

Paper

1 million tonnes per year

The Paper business will be developed by offering resource-efficient alternatives to traditional products



Pressure on prices

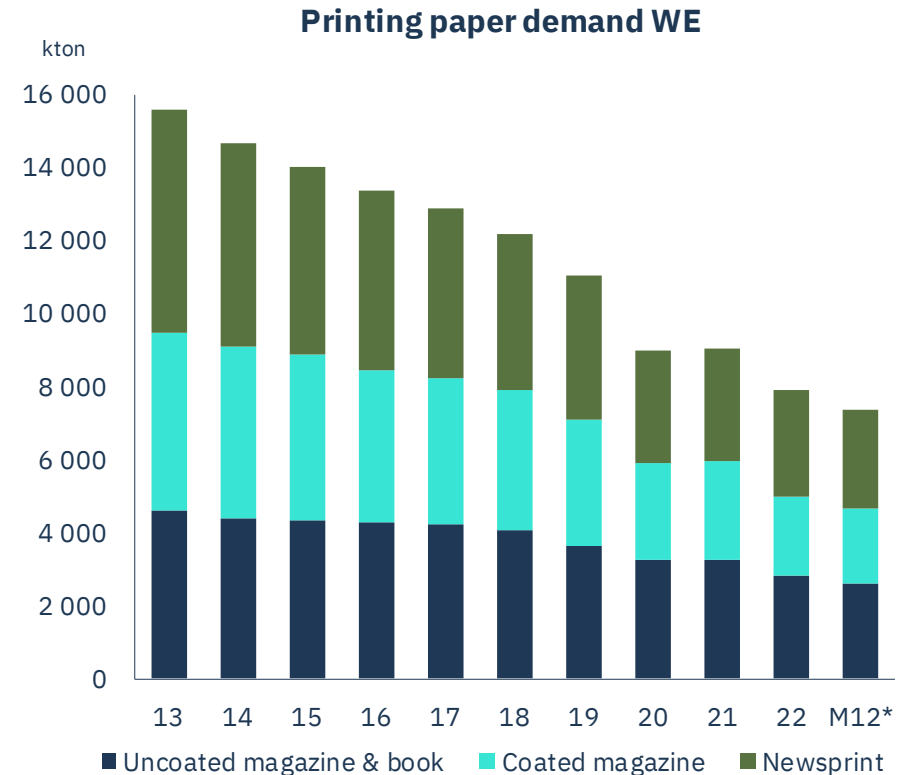
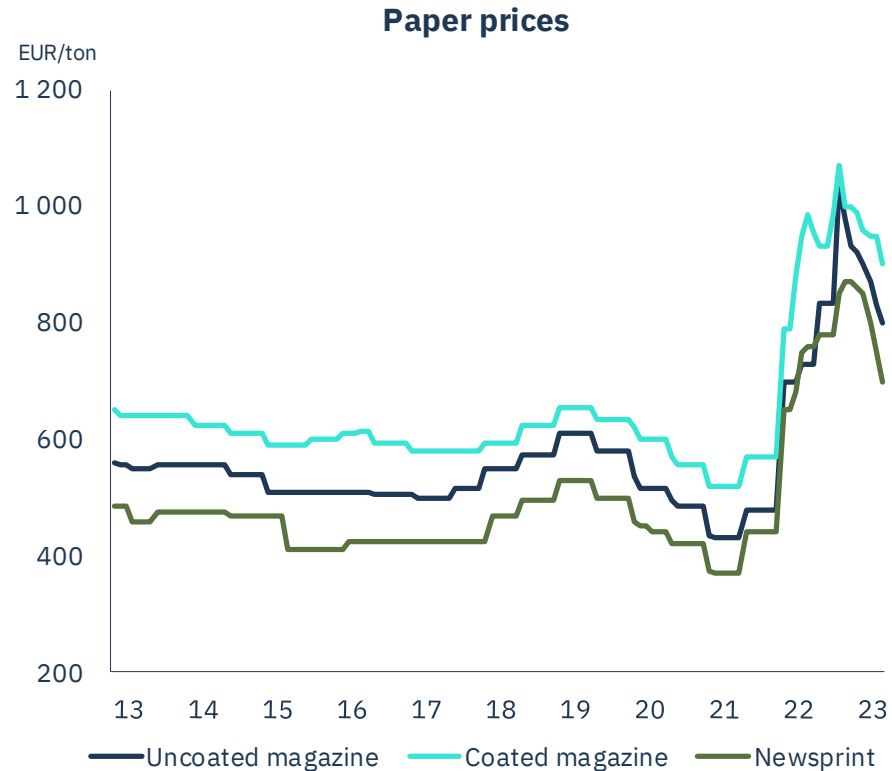

Challenging raw material situation

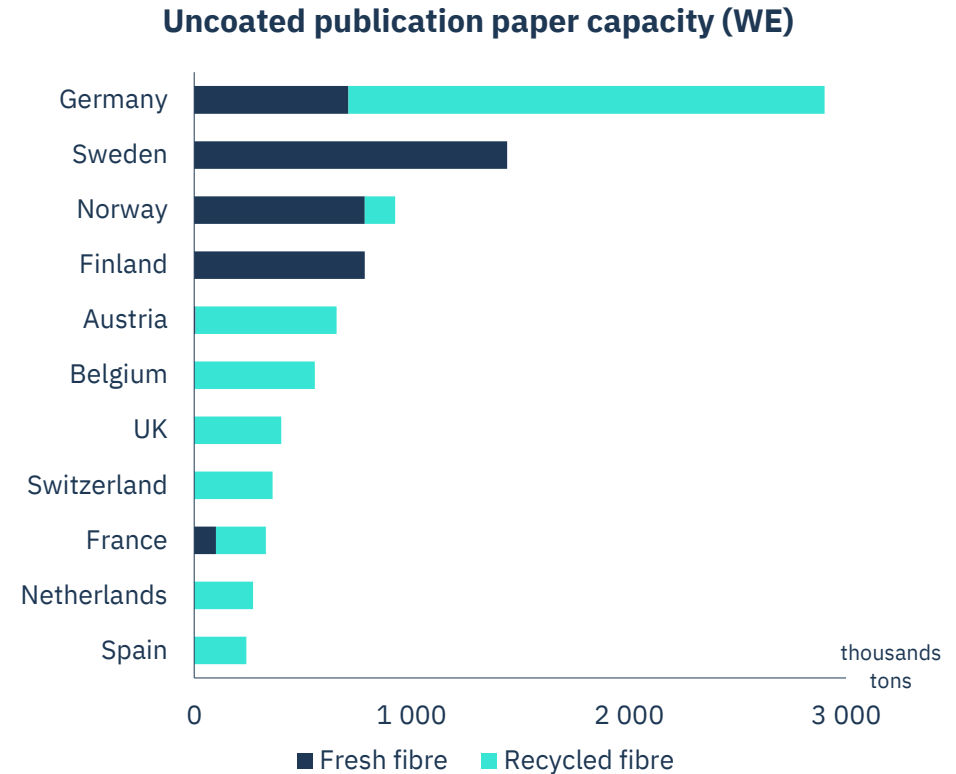
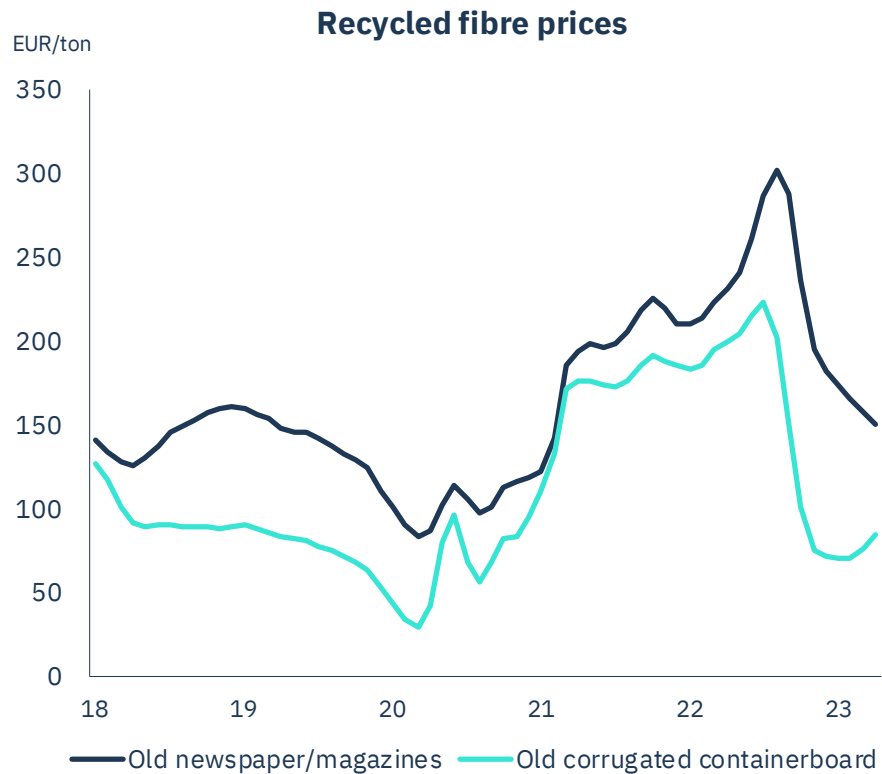

Strong pricing and low electricity bill

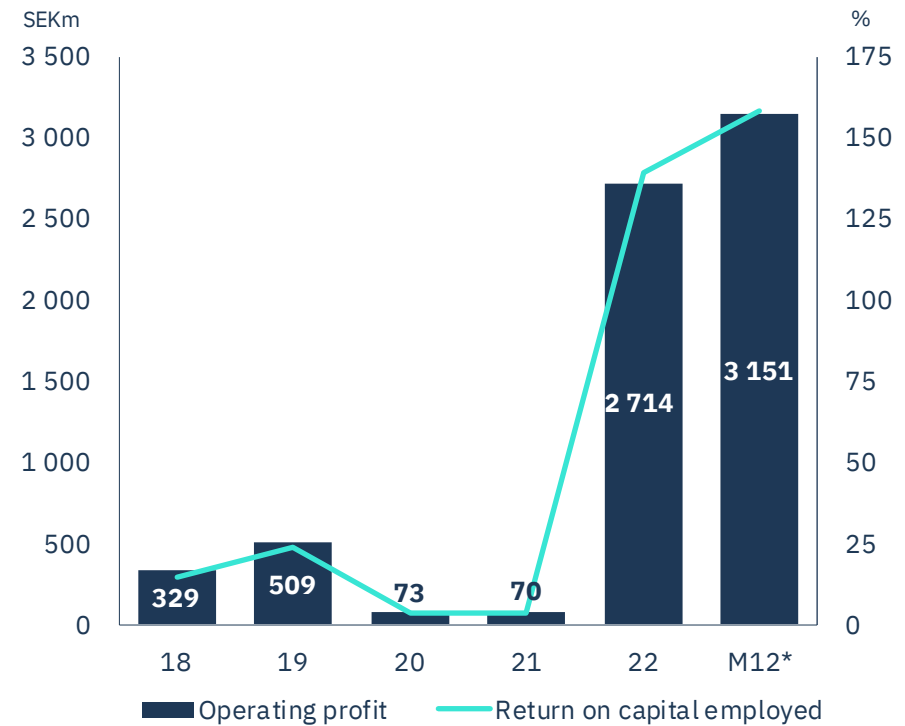
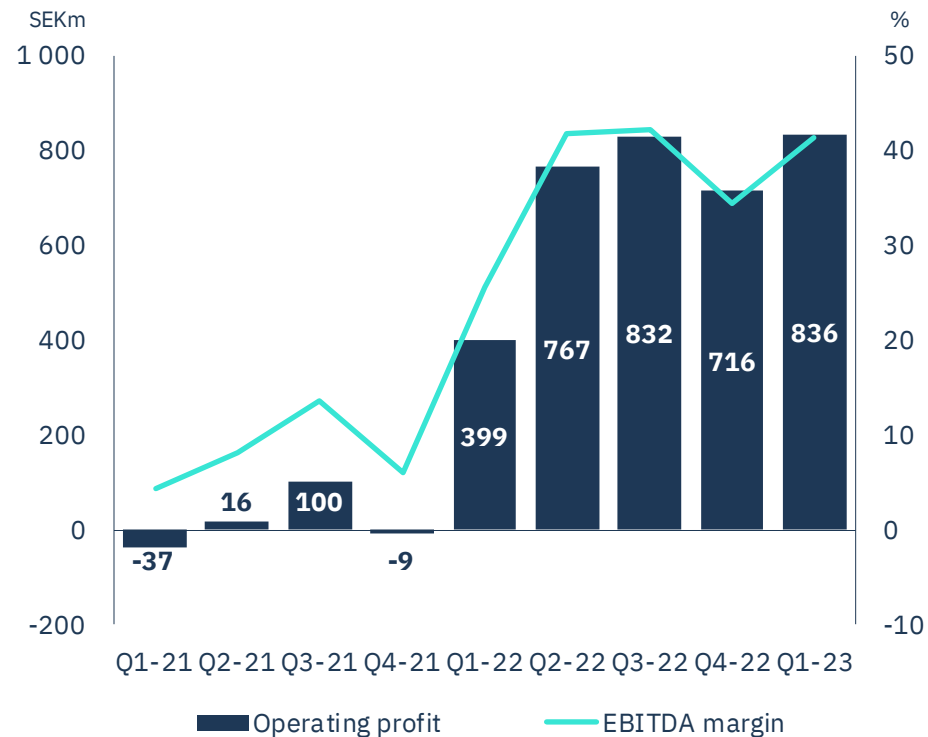

Investing to develop Braviken mill further Improving book position and growing fluting business

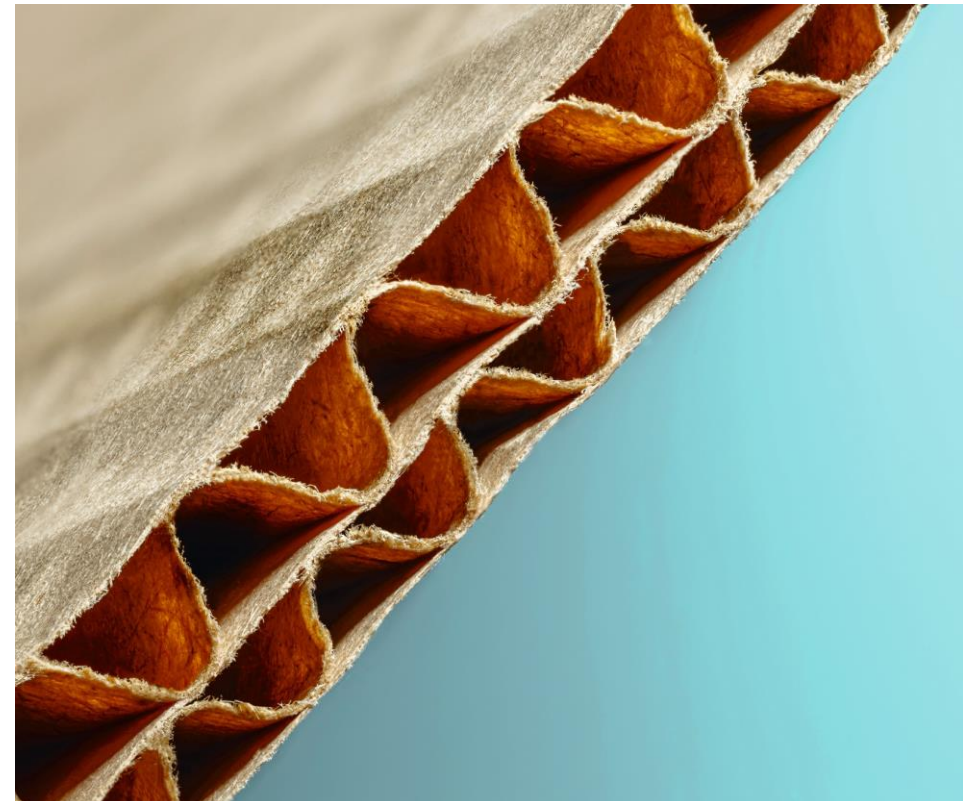

A large warehouse filled with stacks of wood products, with a forklift in the center. The warehouse has a high ceiling with exposed wooden beams and several bright lights. The stacks of wood are neatly arranged on pallets, and the forklift is positioned in the middle of the aisle, carrying a load of wood. The overall scene is well-lit, highlighting the texture and color of the wood.

Wood Products

1.5 million m³ per year

The Wood Products business will grow through products and solutions for sustainable construction

Wood product prices stabilising

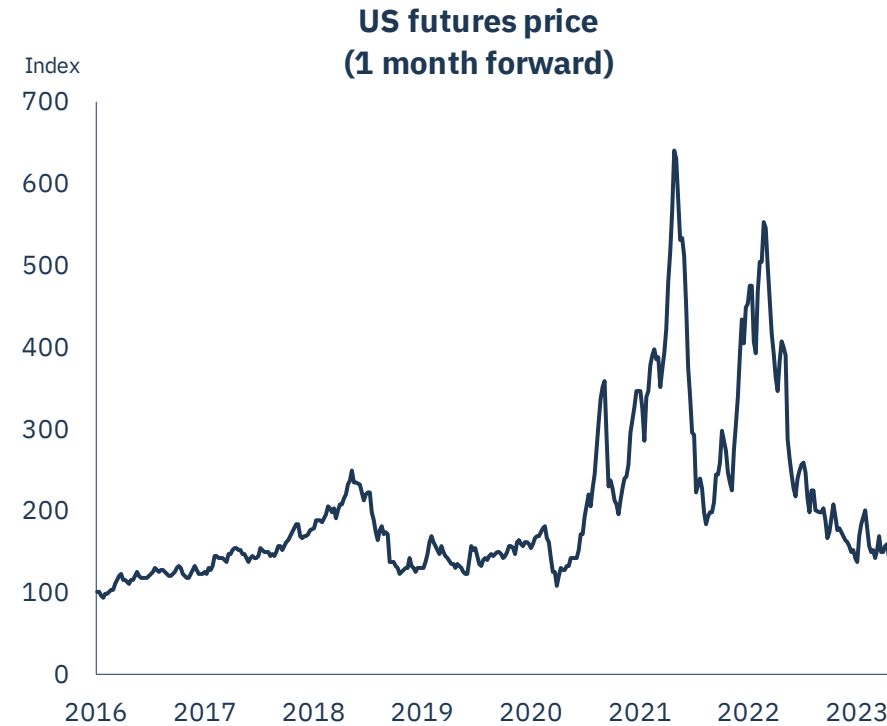
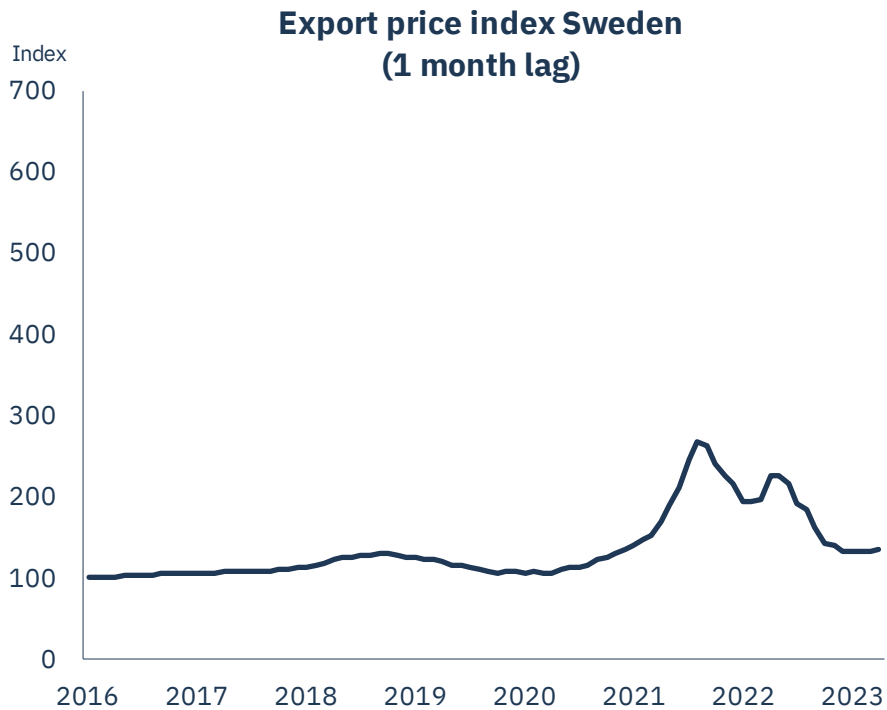

Prices stabilising at historically high levels

Lumber costs 20% higher than before the boom

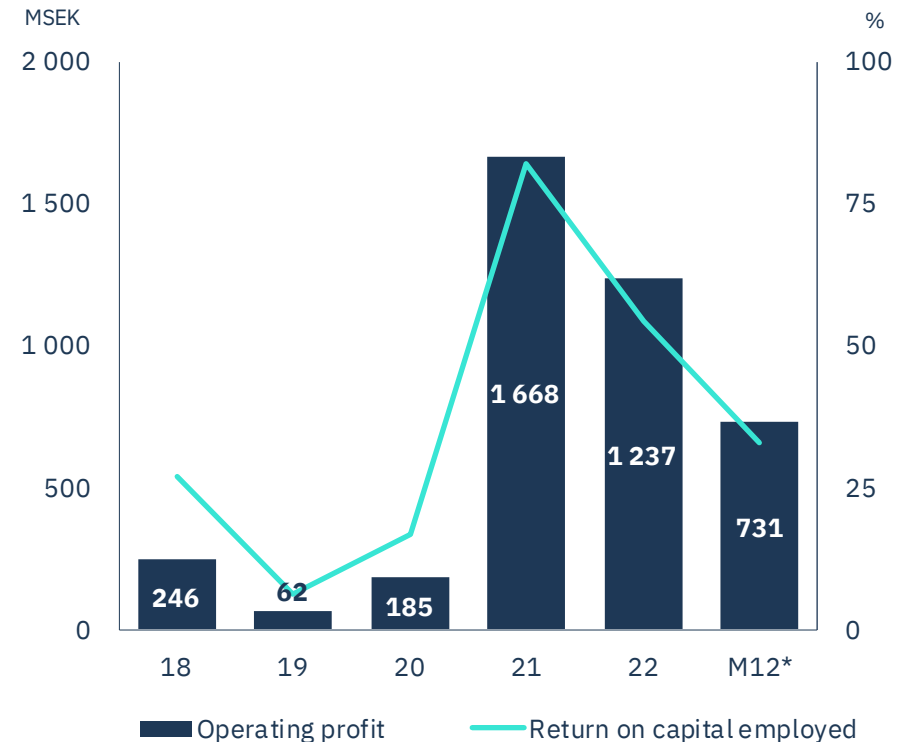
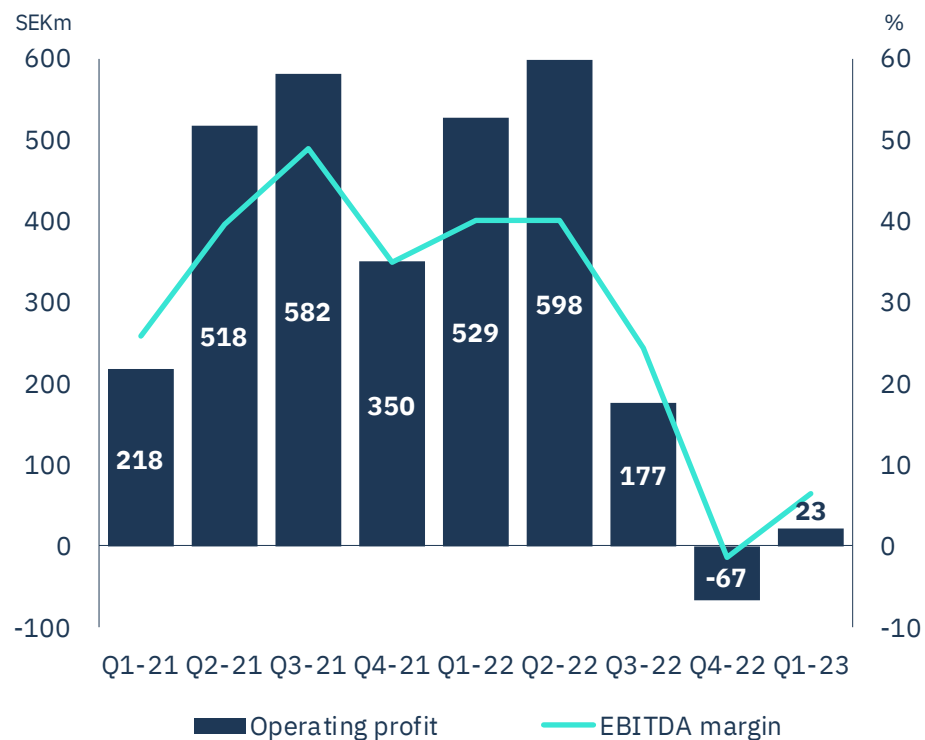

*Q2-22 – Q1-23.

Buildings accounts for 38% of global emissions

Concrete & steel are energy intensive & large emitters

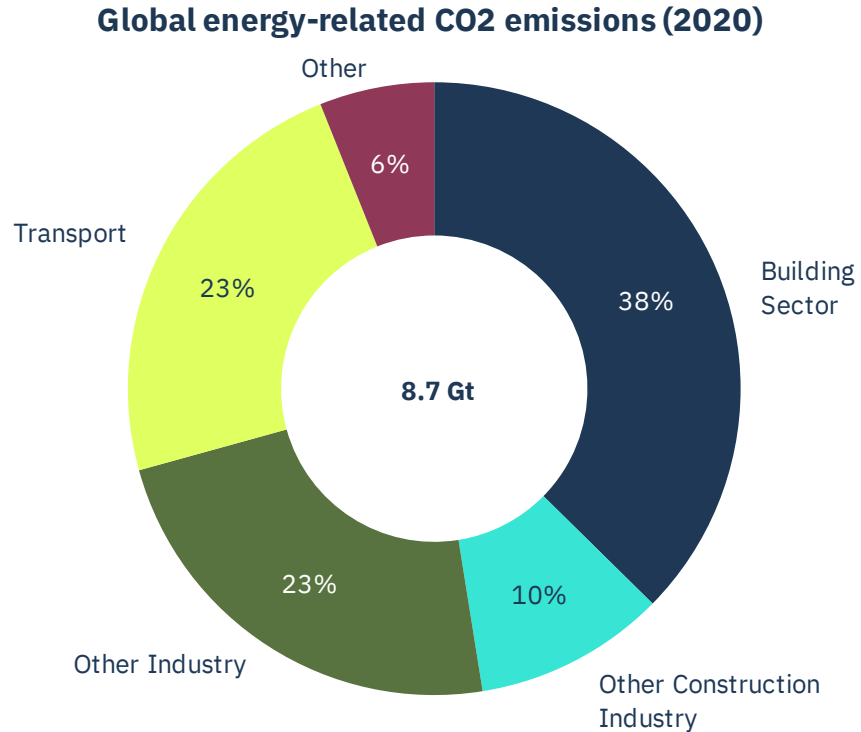

Wood an alternative to concrete & steel

Price of wood & steel tracks concrete over time

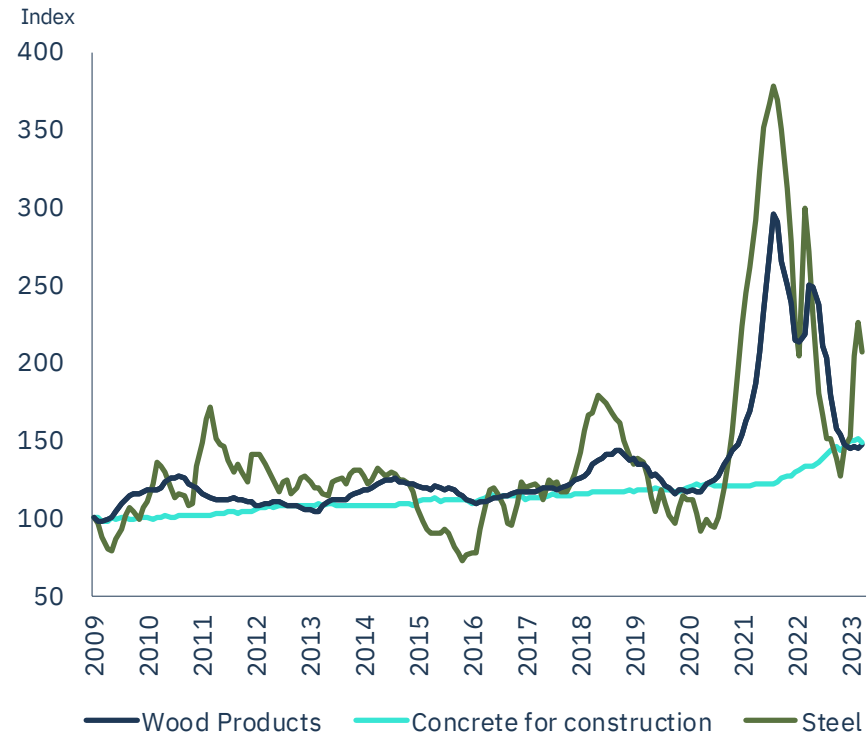
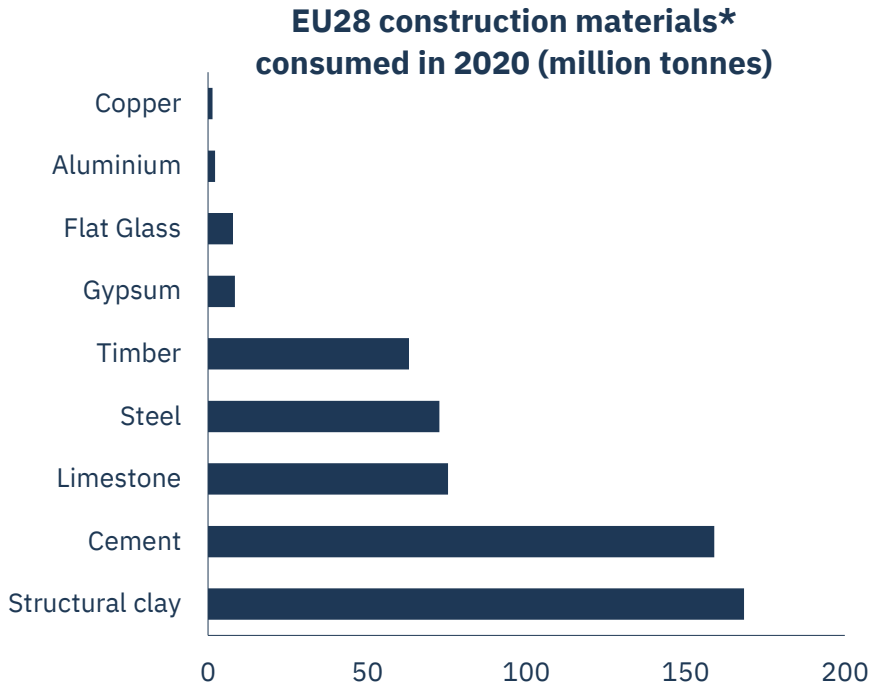

Wood availability a concern in many regions

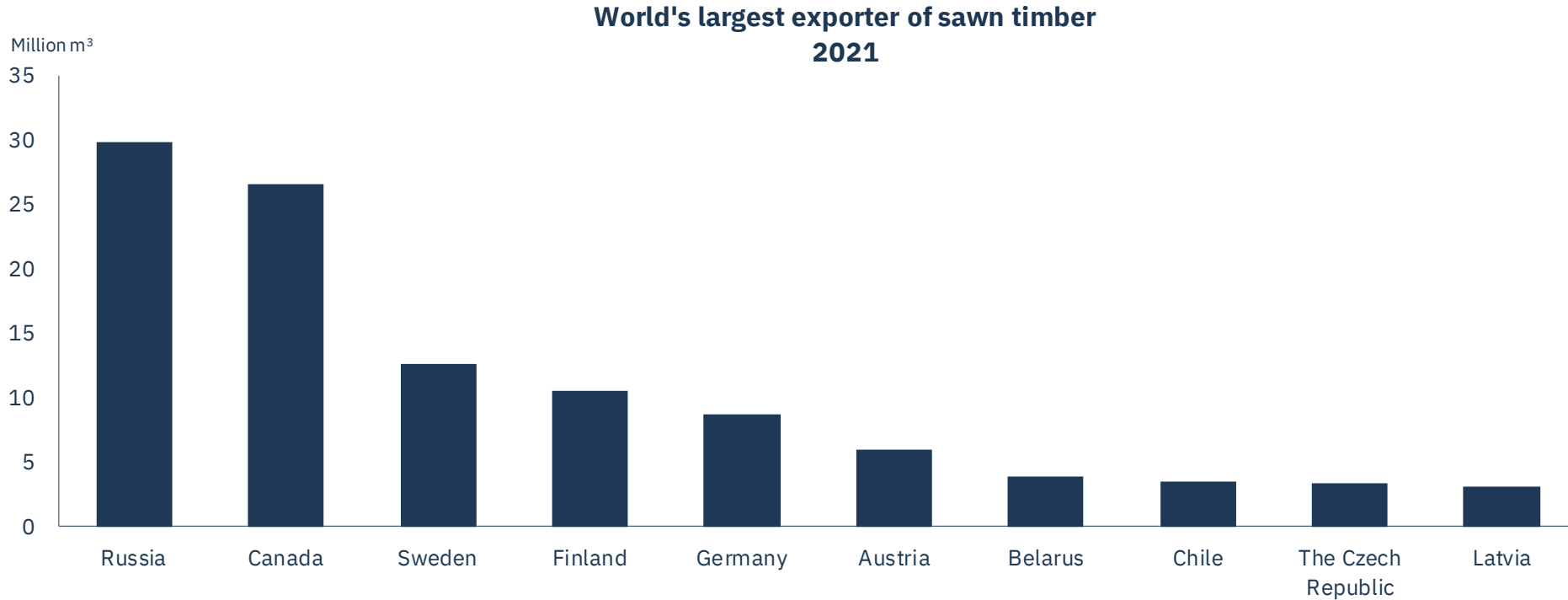

Ambition to grow value & volume

- Ongoing SEK 400 million investment programme at Iggesund Sawmill
- Establishing a logistic hub at Braviken for GLT
- Investing to expanding CLT production by 50%
- Evaluating a new saw mill with SCA in northern Sweden

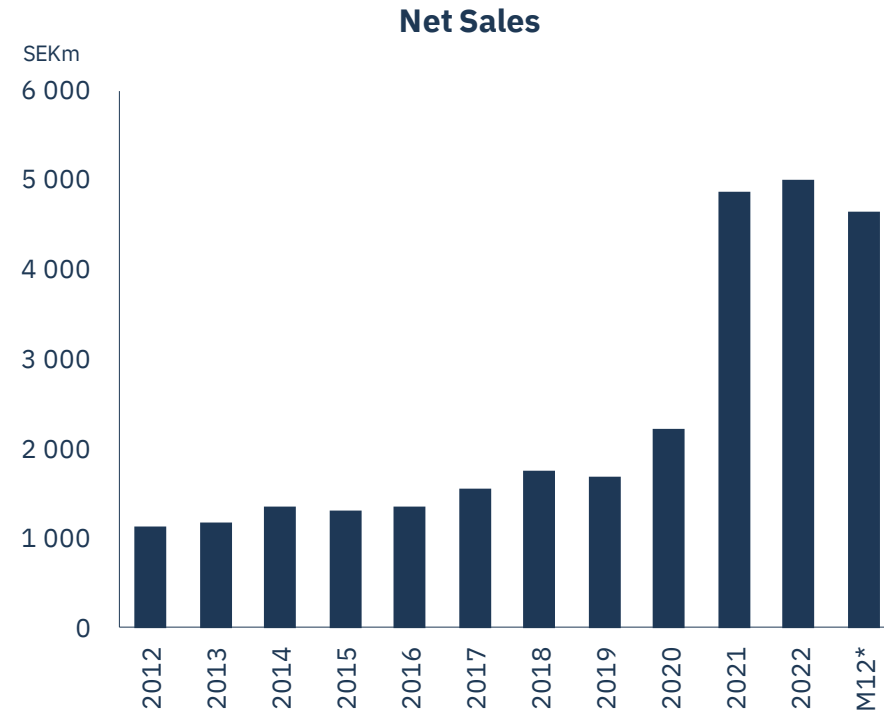

Renewable Energy

1.8 TWh per year

The Renewable Energy business will grow by establishing wind power on Holmen's own land



Energy still a scarce resource in Europe

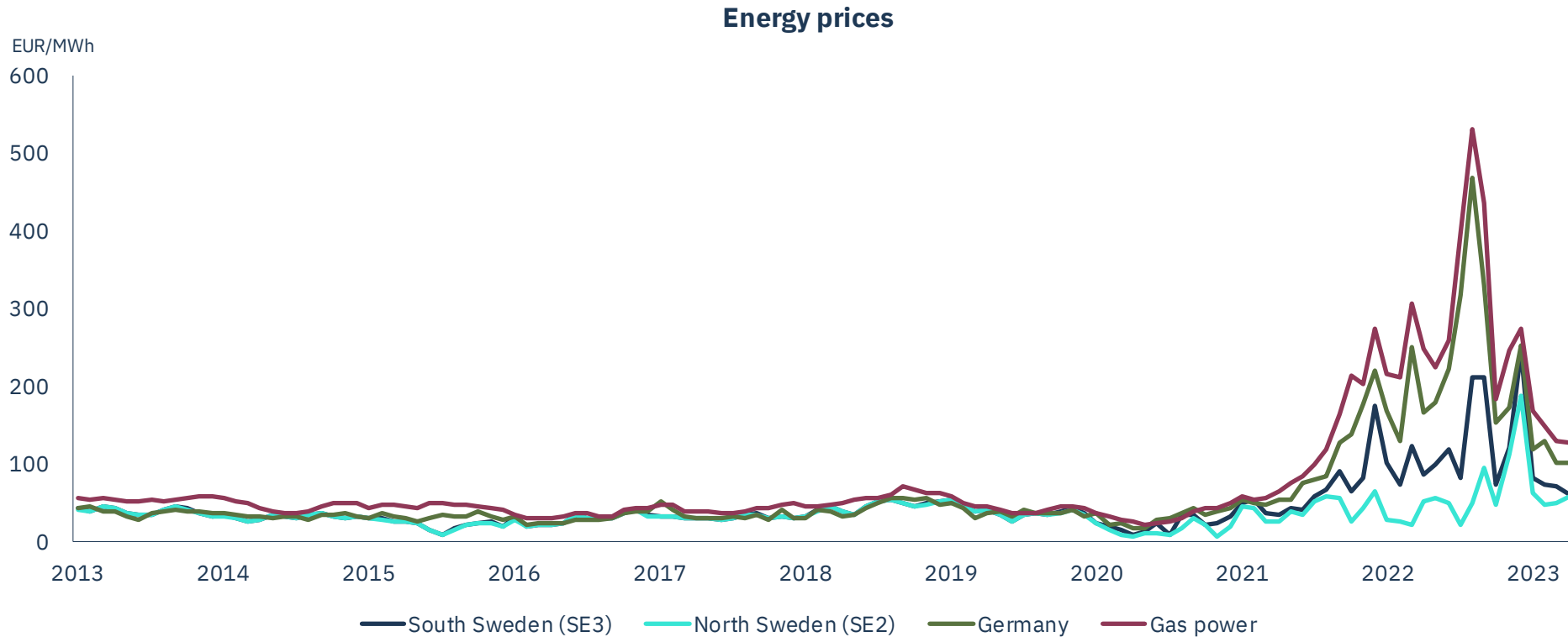

Another strong quarter

Price in northern Sweden averaged 600 SEK/MWh

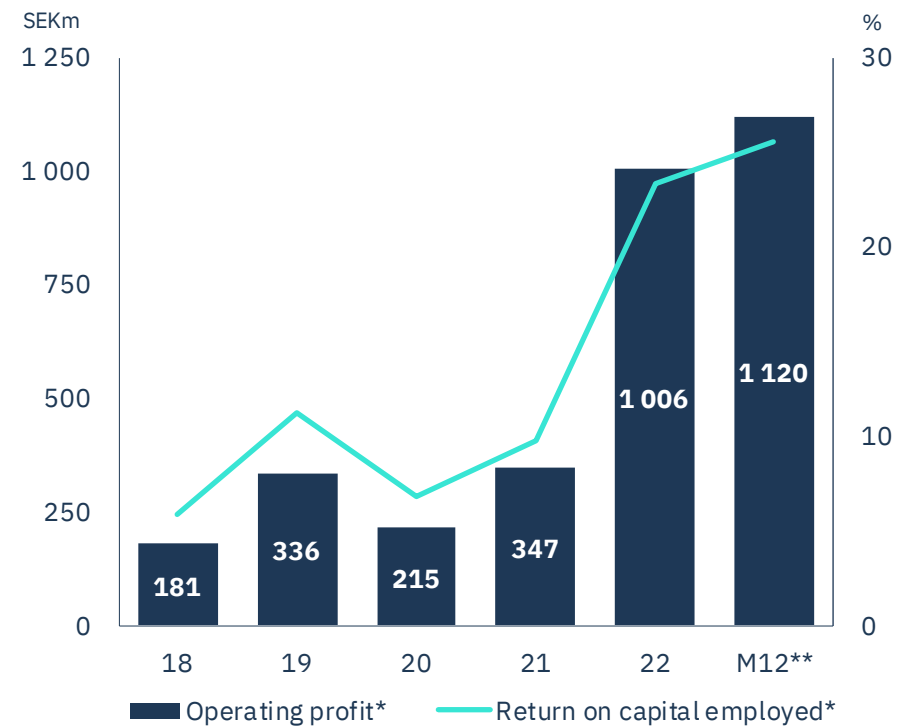
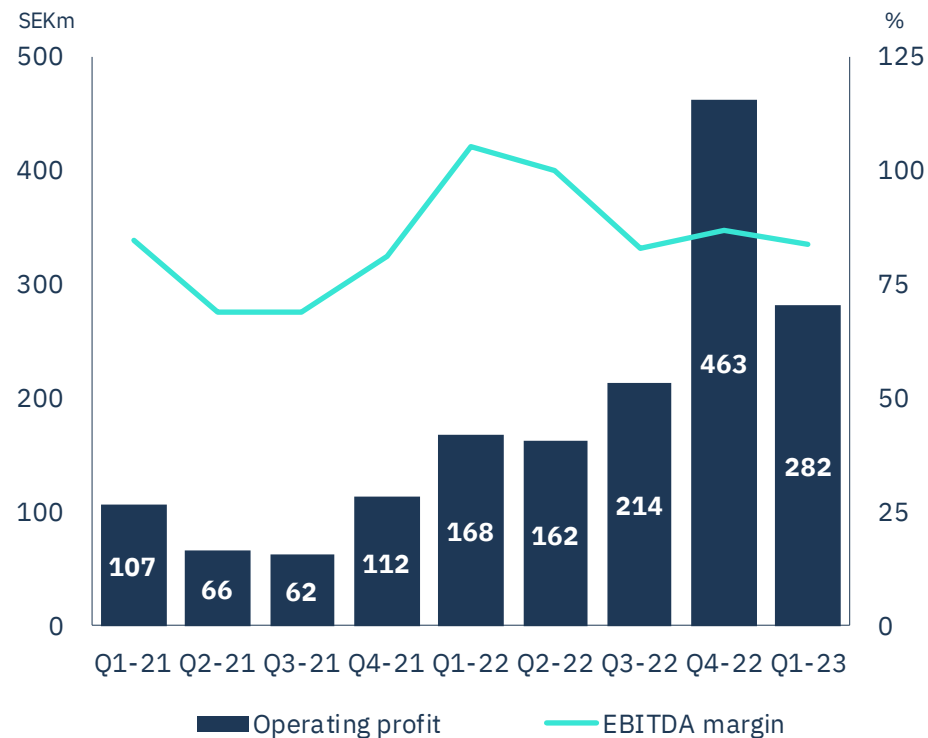

Hydro flexibility pays off

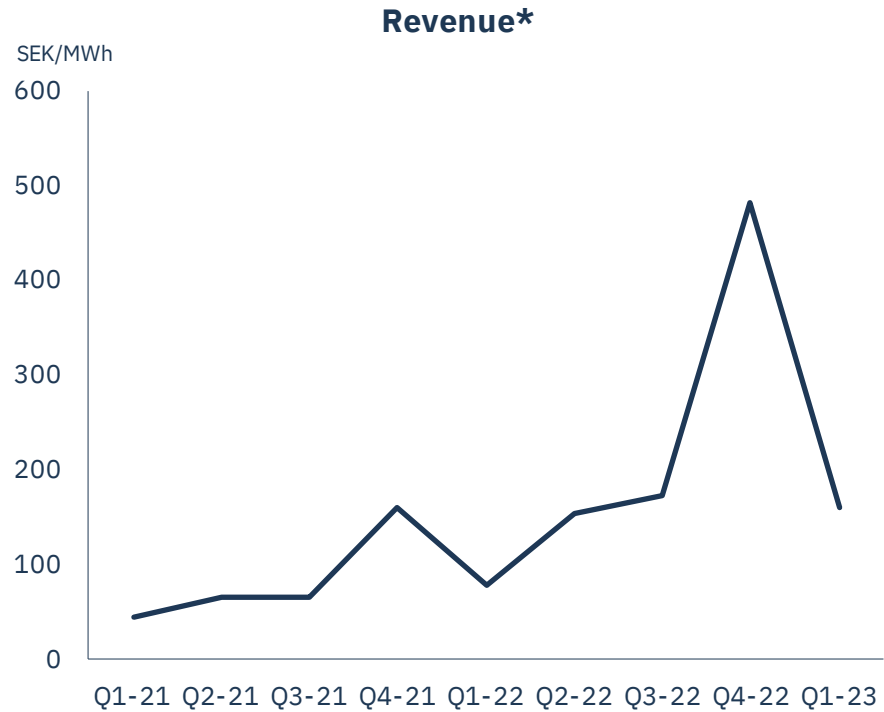

EU heavily dependent upon fossil fuels

1/3 was imported from Russia

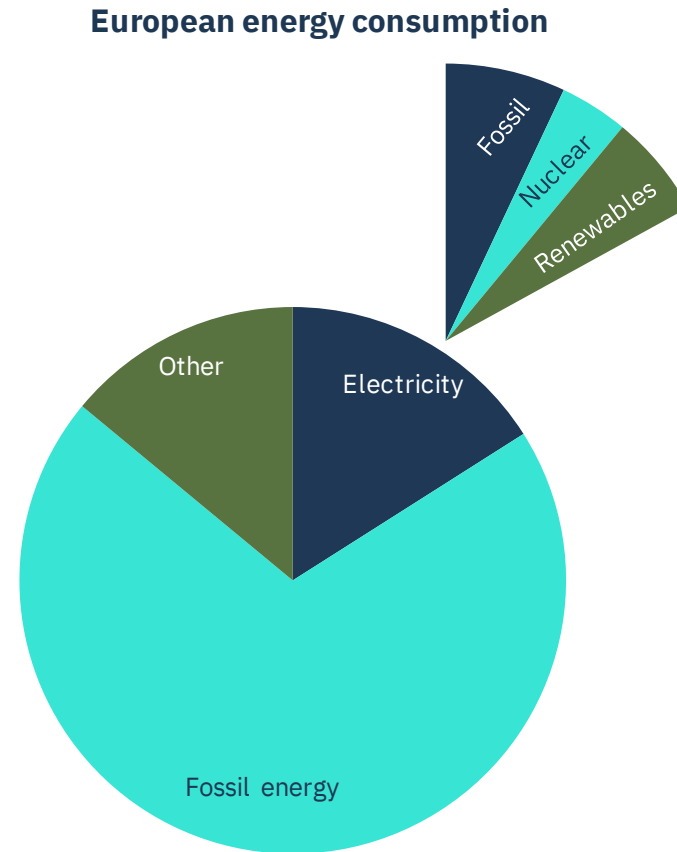

Surging electricity demand when decarbonising



40% growth in renewables through Blåbergsliden & Varsvik



Financial performance



Our business model proved itself

28% operating margin

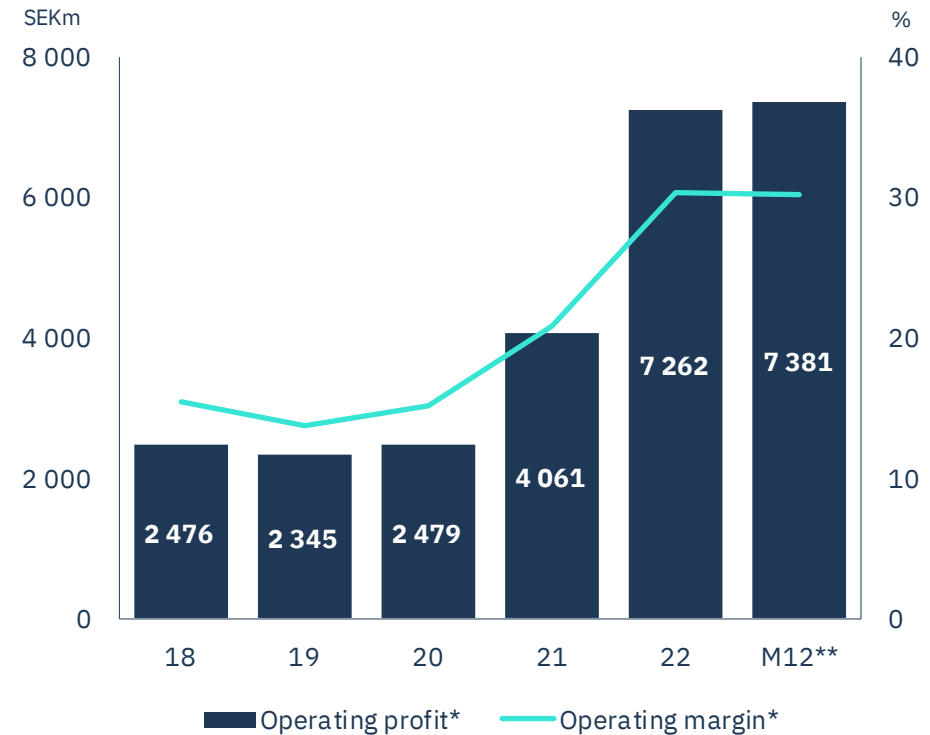
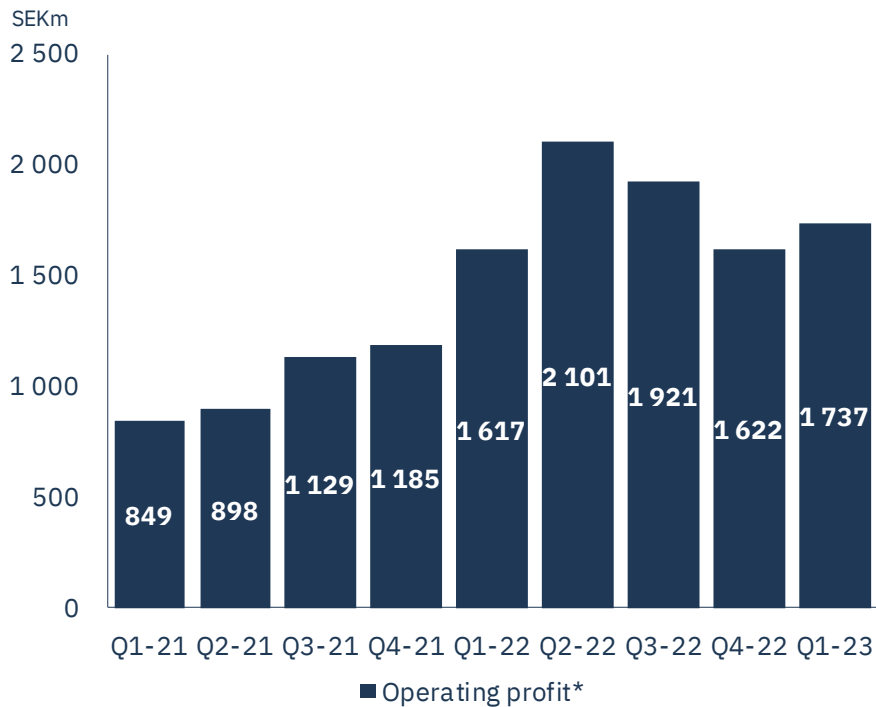

*Excl. items affecting comparability.

**Q2-22 – Q1-23.

SEK 1.8bn free cash flow in Q1

Essentially debt free at end of quarter

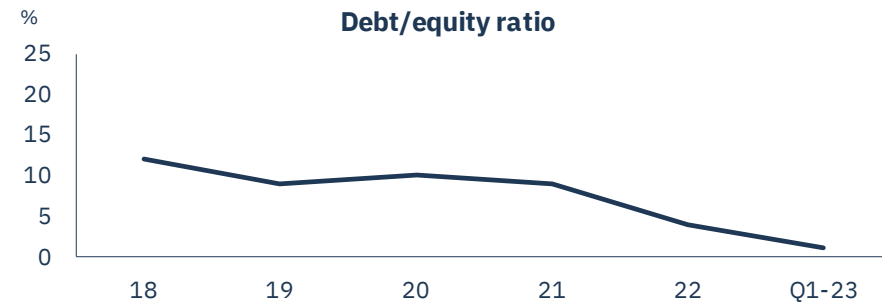
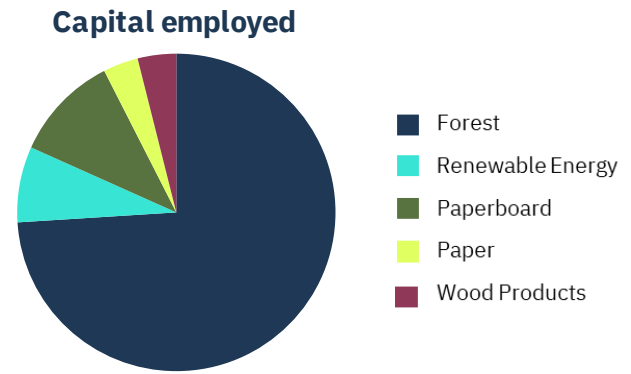
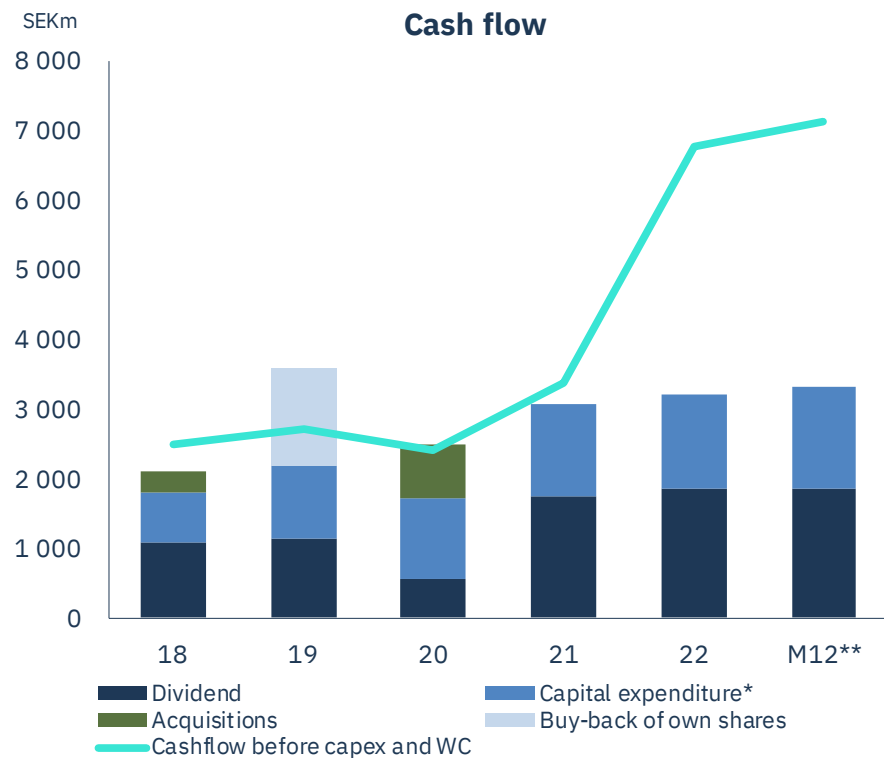

Increasing our contribution to the climate

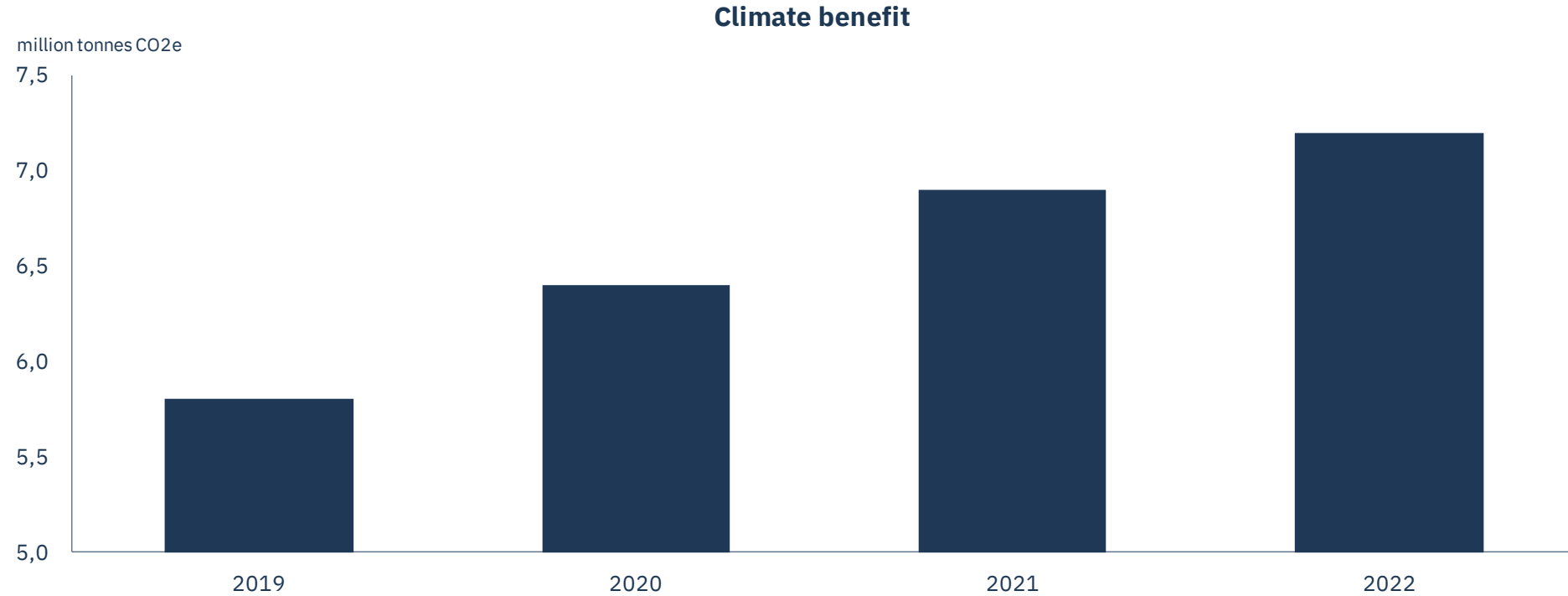

HOLMEN

holmen.com